

Power flags

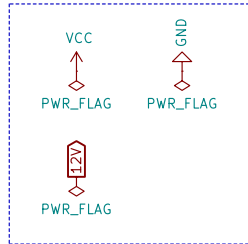

LED IN & OUTPUTS

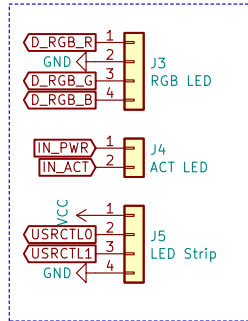

MCU / Arduino Nano v3

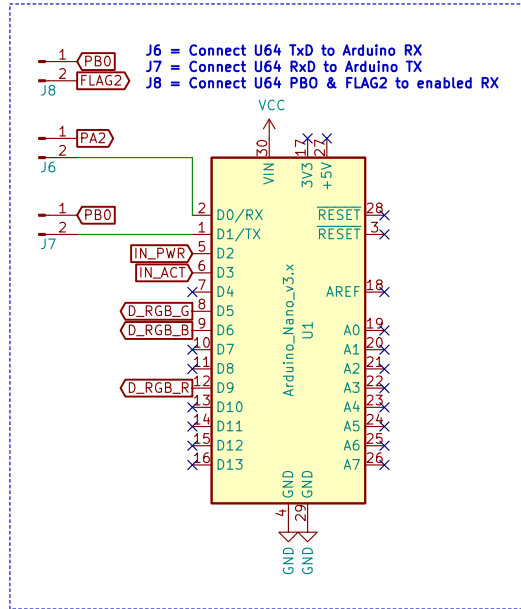

USERPORT Socket to U64

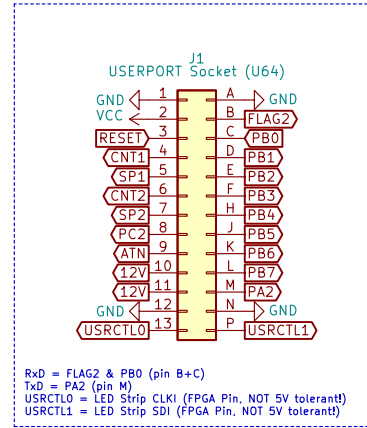

USERPORT passthrough header

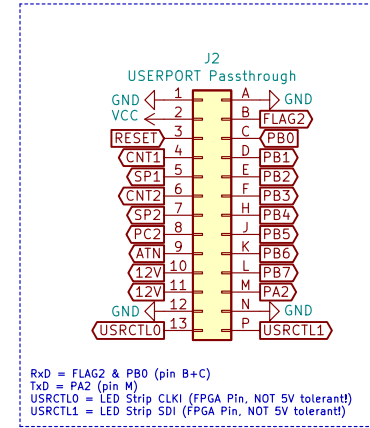

by TSB

Sheet: /
 File: u64_rgb_led.sch

Title: U64 RGB LED CONTROLLER

Size: A4 Date: 2020-11-08

KiCad E.D.A. kicad (5.1.7)-1

Rev: v.0.1

Id: 1/1